



Click for
Certificate
of Listing

DuraTrench

manufactured by Eric'sons



INSTALLATION GUIDE

STOP! Please read before proceeding!

DuraTrench trench drain systems are shipped with temporary plywood tops to protect the product from shifting, warping, cracking, etc. during transit and installation.

- **DO NOT EVER** remove the plywood until you are ready to install covers.
- **DO** protect the plywood covers prior to installation. Careful consideration should be given to protect the plywood from swelling and warping due to excessive exposure to outdoor elements. The plywood is meant to be a temporary protective cover and it is not intended for long term exposure to the elements.

DISCLAIMER

This guide is intended to aid in the installation of DuraTrench systems. There are many different applications and situations for the use of this product. All installation procedures must be carefully evaluated prior to installation. This guide provides best-practice procedures for the most common applications of the system. If additional installation methods or field-modifications are necessary, it is recommended that an experienced installation contractor be utilized to evaluate site conditions, and proceed with installation in accordance with the recommended methods outlined in this guide, and in accordance with local, State and Federal regulations, as required. DuraTrench is not responsible for system failure as a result of noncompliance..

TABLE OF CONTENTS

PLANNING BEFORE INSTALLATION	
RECEIVING AND STORAGE.....	1
LAYOUT AND SHOP DRAWING.....	1
EXCAVATION.....	2
FORMWORK.....	2
STRUCTURAL REINFORCING (REBAR).....	2
DOWELS AND EXPANSION.....	3
CONCRETE.....	3
WEATHER.....	4
SAW CUTTING.....	4
FOOTINGS.....	4
TOOLS AND SUPPLIES.....	4
UNCRATING and STAGING MATERIALS.....	5
INSTALLATION METHODS.....	6
STAKING THE TRENCH.....	7
MUD SLAB TESTING.....	7
FORMED EDGE.....	7
OVER MEMBRANE.....	8
FIELD MODIFICATIONS.....	9
TURNS.....	9
TEE CONNECTIONS.....	10
INVERT MODIFICATIONS.....	11
END PLATES.....	11
INLET / OUTLET FITTINGS.....	12
ATTACHING PIPES.....	13
ATTACHING PIPES INSIDE UTILITY TRENCH (DTUT).....	13
SEALING JOINTS.....	13
SEALING CHANEL BODIES: DTPF / DCF / DTFR.....	13
WITH GASKETS.....	13
WITH SLUR.....	14
WITH SLPP/CP.....	14
WITH SLPF/CF.....	15
SEALING CHANNEL BODY: DTSS.....	16
WITH BOLTED FLANGE & SEALANT.....	16
WITH WELDING.....	16
SEALING CHANNEL BODIES: DTDCPF / DTDCCF.....	17
WATERPROOFING AND MEMBRANES.....	17
TRENCH AND FLOOR DRAIN FLASHING COLLARS.....	17
OUTLET PIPE FLASHING COLLAR.....	18
BEST PRACTICES WHEN NO MEMBRANE EXISTS.....	19
FLOOR & LINEAR DRAINS - NEW CONSTRUCTION CONCRETE SLAB.....	19
FLOOR & LINEAR DRAIN INSTALL FOR EXISTING CONCRETE	
SLAB RETROFIT.....	20
LEAK TESTING.....	20
LEAK TESTING SINGLE WALL DRAINS.....	21
LEAK TESTING DOUBLE (DUAL) CONTAINMENT DRAINS	
(DTDCPF & DTDCCF).....	21
QUALITY CONTROL CHECK.....	22

CONCRETE SURROUND PLACEMENT.....	23
MIX DESIGN.....	23
VIBRATION.....	23
ANCHORING POUR.....	23
FLOATATION.....	23
FINAL POUR.....	24
FINISHING.....	24
DURATRENCH FORMING SYSTEMS FORM REMOVAL.....	24
DTTF.....	24
DTSF.....	25
INSTALLING THE GRATES / SOLID COVERS.....	25
REMOVING THE TEMPORARY PLYWOOD COVER.....	25
CLEANING THE CHANNEL'S INTERIOR.....	25
GRATE SPACING.....	25
CUTTING GRATES.....	25
GRATE TOGGLE LOCKS.....	26
GRATE SADDLE CLIPS.....	26
GRATE 4-CORNER BOLTING.....	26
CLIP LOCKS.....	26
SEALING SOLID COVERS.....	27
DURA TRENCH RAPID PROGRAM.....	27

Need help Installing??
Allow Eric'sons Construction Services to install for you!

Mobile Installation Crews are Available Nationwide for Subcontracting
Please call for a free quote!
770-505-6575 ext 2020
M-F 8:00AM - 7:00PM EST

FOREWORD

DuraTrench linear drainage systems are engineered with ease of installation in mind. This manual is intended to help installers understand the basic principles of system-drainage installation. All of these principles apply to each of our drainage systems. Please note that there are many additional installation methods and techniques, not covered in this manual, which may be used for various applications by an experienced installer. It is the installer's responsibility to determine the best installation method for each application and product. If there are any specific concerns or conditions, please contact us for guidance.

PRODUCT TERMINOLOGY

Trench Drain

PLYWOOD IN TOP OF TRENCH PROTECTS DURING CONCRETE PLACEMENT AND GIVES INSTALLER A PLACE TO ATTACH BRACES AND MAKE LAP CONNECTIONS.

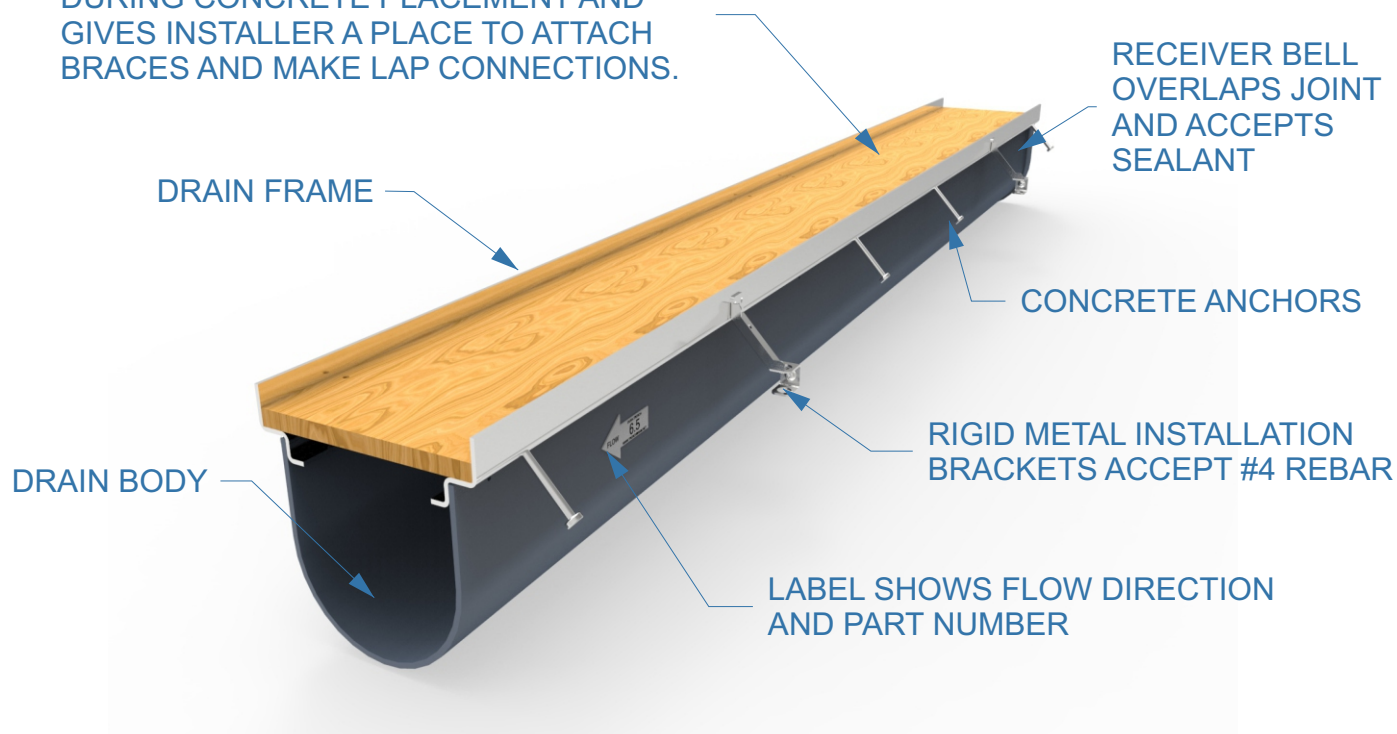

Slot Drain

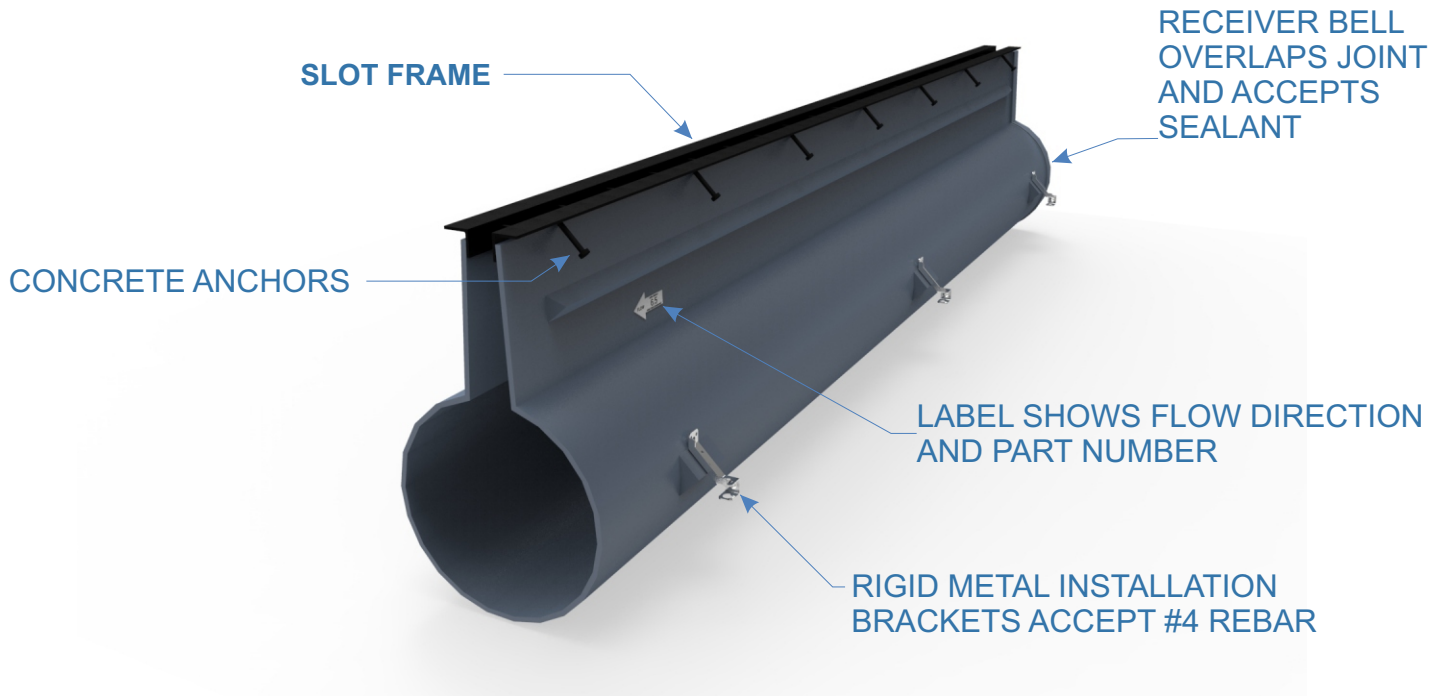

Utility Trench

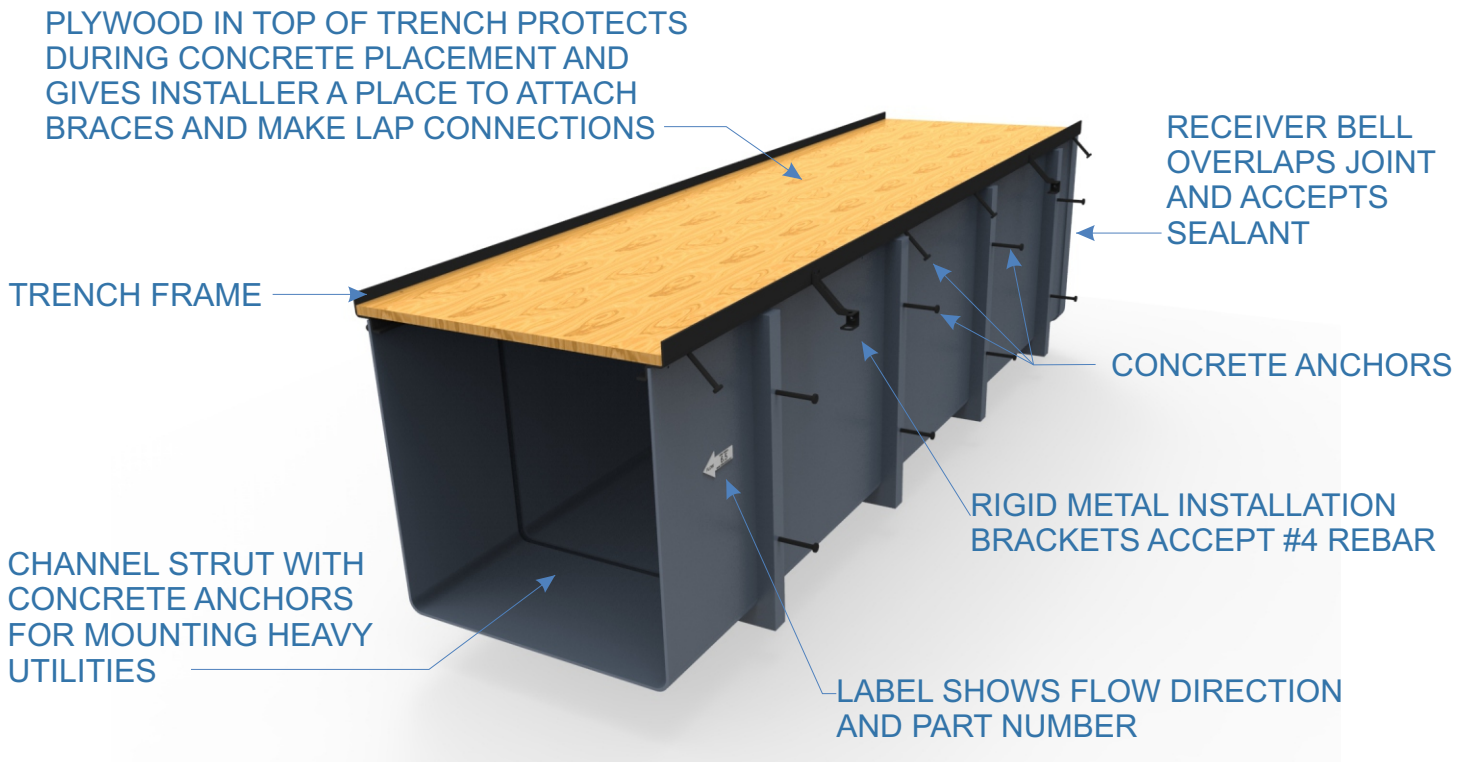

RECEIVING & STORING MATERIALS



Dura Trench drainage systems arrive on a wooden pallet. Before accepting the delivery, visually inspect the pallet and the contents for any damage. If there is any damage, please contact us IMMEDIATELY.

After accepting the materials, it is important to store them properly. Dura Trench materials topped with temporary plywood covers must be stored under a roof or a tarp to keep them dry. Failure to do so can result in the system warping. Secure your materials to prevent damage and theft.

LAYOUT & SHOP DRAWINGS

Each pallet and individual pieces of channels are marked with identifying information that you will need for installation. These pieces of information correlate between the pallet, channel, and the layout found on the shop drawings.

Pallet Frame

Each pallet frame is marked with TD or SD and end with a number. These numbers correlate directly to the Dura Trench Shop drawings, included with your pallet.

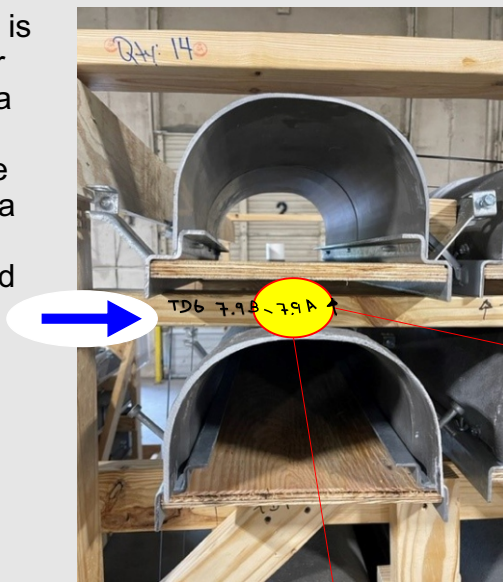

Channel Flow Stickers

Individual channels are pasted with a directional flow sticker. The number on the sticker indicates the channels depth at the end of the channel and is also shown on the shop drawing and details that piece's placement in the channel run.

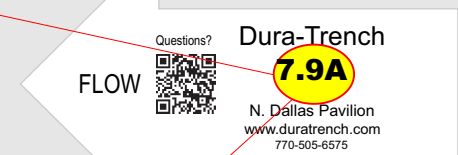

Shop Drawings

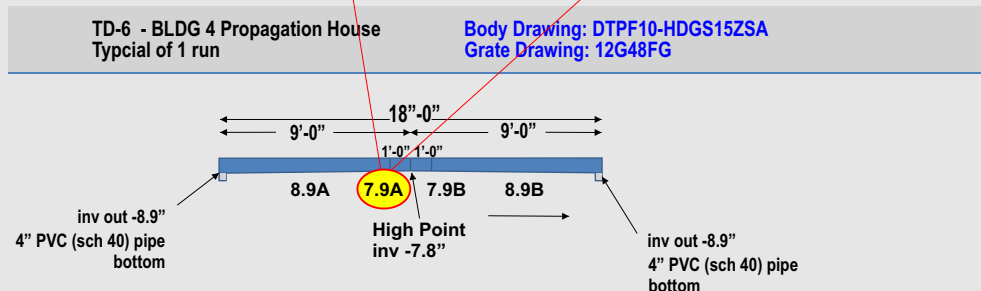

PLANNING BEFORE INSTALLATION

EXCAVATION

Before excavating, contact your local authority to mark existing underground utilities. Once they've been marked, dig around any utilities, by hand, to determine their exact location and depth before proceeding.

Excavate wider and deeper than the parts that you are installing. Consult the construction documents (typically the structural or architectural details) to determine the volume of concrete encasement required around the Dura Trench system. The surrounding thickness should be a minimum of 4", but can be significantly more depending on the project requirements.

While excavating, carefully control both the line and grade. If the excavation is too narrow there will not be sufficient concrete thickness surrounding the system. If it is too large, additional concrete will be required. The proper excavation depth is determined at any given location by taking the part number (which indicates depth) and adding the number of inches of concrete required under that part. The generally accepted practice is to use a laser level (preferably one with a single slope capability) to verify the depth of the excavation as you proceed. It is a good practice to pull a string line on both sides of the excavation to verify the trench width before proceeding with any next steps.

Once the excavation is complete, the soil beneath the excavation site should be properly compacted. If the ditch is not properly compacted, it can lead to premature failure of the Dura Trench system, leaking of joints, or cracking of the concrete surround. If your project calls for a gravel base, install before proceeding.

FORMWORK

Formwork should be set after the excavation and soil-compaction is complete. When possible, drive stakes or pins for mounting the formwork lower than the edge of the form. This will allow you to hang the trenches on top of the forms without having interference with the stakes. Brace all of the forms to ensure that they do not move when the concrete is placed. Any movement of the concrete formwork can affect the finish elevation and alignment of the linear drain.

STRUCTURAL REINFORCING (REBAR)

If your project requires a vapor barrier, install it before the structural steel reinforcement. Ensure all seams and penetrations are taped before continuing as it will be almost impossible to do so later on in the process.

The structural reinforcing steel should be installed according to the construction documents.

NOTE: This step often causes significant delays in future installation steps. We recommend checking the fit of the system prior to installing the entire structural cage. Use a string line, or make a jig, that represents the drain to ensure the rebar is properly placed and will not interfere with the drain,



When the structural steel is not installed straight or installed at an improper elevation, it results in the system not being compatible with the frame. By controlling the line and grade as it is being installed, you can avoid this common problem.

DOWELS & EXPANSION

The system you are installing will either be designed to be *isolated* from the surrounding materials or *tied* to the surrounding materials.

Isolated systems are meant to move at the joint between the encapsulation concrete and the surrounding materials. In this case, there will be some sort of expansion material at that interface. The expansion material should be installed to the full depth of the interface. There should not be any rigid materials touching one another. In many cases the adjacent concrete is doweled through the expansion material. If this is the case, smooth dowels should be used. All smooth dowels must be level and perpendicular to the adjoining face. If this is not done properly, cracking will occur around the dowel bar. The expansion material should be sealed per the project specifications.



Non-isolated linear drain systems are often tied to the surrounding material with dowels and do not contain expansion material. In this case, it is best to use rebar (not smooth dowels.) The rebar is typically anchored into the existing material with epoxy or other suitable method.

You should verify the length of all dowels that are to be installed to make certain they do not conflict with the linear drain system before installation. If there is a conflict, you may have to cut them down to size in the field. In retrofit applications, expansion and dowels are required to be installed before the linear drain. However, in new construction, they can be installed after the drain so long as the dowels, and drilling, do not penetrate the drain.

CONCRETE

It is very important to study the concrete mix design before the project starts to ensure the mix is suitable for placement around the drain. In most cases a combination of reinforcing steel, wide trenches and a stiff flow slump will not allow the concrete to properly flow around the trench drain.

Most trench drain applications require a slump of around 5" or greater. Trench drains wider than



24" should use a slump of 7"-8". In order to not compromise the water cement ratio of the concrete, a plasticizer is recommended. In some cases, the reinforcing cage can be reduced with the addition of steel or glass fibers. This can be helpful achieve proper flow of the concrete under these structures.

Proper vibration of the concrete is also required to ensure all air pockets are removed from the concrete. We recommend using a pencil vibrator to do this. The vibrator should be inserted into the concrete at regular intervals.

WEATHER

You should consider the weather forecast before proceeding with the installation. Any precipitation will naturally flow toward the installation site and can compromise the excavation and/or soil load bearing capacity. It is best not to excavate the ground until you see that there will be a sufficient number of dry days to complete the excavation. If this is not possible, it's very important to evacuate any water that drained into the excavation site as quickly as possible. Doing so will minimize the potential of the sidewalls caving in, resulting in damage to the sub soil compaction.



SAW CUTTINGS

To prepare for saw cutting a slab to install a linear drain there are a few important things to consider. Utilize the shop drawing to mark the layout on the floor. Be sure to add the required concrete encapsulation to both sides of the layout. The encapsulation should also be added to each end of the layout. Extra removal may be desired around outlet pipe connections and basins to allow for personnel to complete the installation. If an excavator will be used, measure the bucket and teeth and ensure the saw cut with will allow for entry. Use chalk lines and clear paint to mark the cut locations once all measurements have been verified.

FOOTINGS

Underground concrete footings can sometimes be in conflict with concrete encasement or the trench drain itself. It is best to verify the possibility of a conflict before you begin installation. Walk the site, or use the structural plans, to check for conflicts. Any conflicts should be brought to the attention of the design team for resolution.

TOOLS AND SUPPLIES

The tools that are highlighted in this manual focus on the trench installation and will be recommended in the appropriate sections of the installation manual. There are more tools required for more common tasks like excavating, rebar placement, etc. but those are out of the scope of this

guide. The tools recommended in this manual are not the only tools that can be used but they represent the most efficient methods that have been used in the field by other experienced installers.

You will need:

- Sledge hammer or hammer drill with ground rod driver
- Cordless Impact driver with 1/2" nut driver and screw driving bit screws (2" or 2 1/2" drywall, or wood screws)
- #4 rebar for installation legs
- 2" x 4" lumber for bracing trenches
- Tie-wire and lineman pliers
- Masons line (string)
- Laser Level
- Caulk gun and sealant of choice (urethane, silicone, liquid nails, ...)

UNCRATING & STAGING MATERIALS

Dura Trench systems arrive pre-assembled and stacked on a pallet. Remove the bands and pallet wood as necessary to access the material. Be sure to keep the pallet wood onsite for bracing the channel to aid in installation. If you will be using U-shaped rebar installation bars, go ahead and insert them into the installation brackets on the sides of the trench or slot pipe rails, then tighten the bolt to secure them to the drain. Note that if you are using straight bars do not put them in at this time.

The installation of your channel drain should begin at the deep end, or outlet end, of the run. Place the drains beside the trench, in the order in which they will be installed. The trenches are numbered according to the shop drawings provided by Eric'sons Manufacturing (typically the numbers correspond with the depth of the trench at the deep end of the section.) The deepest sections need to be located next to the outlet (pipe or basin). Unless the channel is neutral, the trenches should get smaller the further you move away from the outlet location. Make sure all arrows are pointing toward the outlet piping. All arrows should face the same direction unless you have a high-point in the trench where the trench begins to slope the opposite way. Now, double check that the slope arrows and numbers match the layout on the Eric'sons provided shop drawings before proceeding.

IMPORTANT: The drain pieces will not connect properly if the channels are not positioned correctly.



INSTALLATION METHODS

STAKING THE TRENCH

This method is recommended for installing drains in slab pours and other pours which are quite far from formed or existing edges. In these conditions, drains are not able to be braced from above to other rigid objects. These installation devices will help control the drain's line and grade, as well as brace it against movement.

TIP: Avoid tying the drain to a nearby rebar cage. During the concrete placement, the cage can move pulling the drain out of alignment.

Make sure the drain edge is aligned with a string line. We recommend using this string only to control the line of the drain and not the elevation. Set the string approximately 1 to 3 inches



above the top of the drain so that the center of the string does not sag and touch the drain body and alter the alignment. A laser level or builders level should be used to control the elevation.

Begin the drain installation at the deep end, usually located at an outlet pipe. The first piece is often the most difficult to install, due to the pipe connection. Ignoring the pipe, place the trench in the exact and intended location.

NOTE: If the pipe is not placed in the correct location, it will have to be moved later.

TIP: When using straight installation bars you will want them long enough to drive into the subsoil to maintain alignment and resist flotation. For clay and hard-impacted soils make sure you drive them at least 24" into the soil. For sandy soils you will need at least 36" to 48" into the soil to gain enough resistance against floatation. Larger drains require more floatation resistance.

Hold the first drain section in line with the string ensuring the flow arrow is pointed toward the outlet pipe location. Insert #4 rebar legs into the installation devices on the sides of the trench. The bars



TIP: Repurpose scrap 2x4 lumber, pallet dunnage, or plywood on the jobsite that can be used to screw these joints

need to penetrate the soil deep enough to be very difficult to remove, 18" to 24" in clay soil and 36" to 48" in sandy soil. After double checking that the channel is in line with the string, using an electric hammer, drive the installation bars into the soil. Although the elevation does not need to be perfect at this point, it is best to set the channel 1/2" above the intended elevation. Larger drains require more floatation resistance. Tighten the set screws on the installation devices using a 1/2" nut driver on a cordless impact driver (you can use a ratchet but it will take longer.) Using the laser or builders level, tap on the bars with a hammer to get both ends of the drain to the perfect elevation. **IMPORTANT:** Be sure that the tops of the rebar legs are at least 1" below the top of the drain so that they do not protrude above the finished concrete.

Next drive #4 bars in an x pattern at these installation legs so that the drain can be braced in proper alignment with the string. Have one person push the drain perfectly in line with the string while the other person ties the #4 rebar X bracing with tie wire. Do this on both ends. It is best to use a speed square from the edge of the drain up to the string line to ensure it is perfectly in line with the string. At this point, the first drain section should be set exactly where it should be. Once verified, connect the outlet pipe. (See "Pipe Connections" section for additional instructions on this topic). After the pipe is connected, verify alignment and elevation one more time.

Install the remainder of the channel sections in the same manner, verifying each time that the flow arrows are pointed toward the outlet piping or basin, and that the section numbers are following the shop drawings provided by Eric'sons Dura Trench. Each shallow end section of channel has a receiving bell to accept the next drain section, unless it was intentionally removed by the designer. If required, apply the joint sealant to the bell at this time. (For more detailed instruction on sealing, see the "Sealing Joints" section later in this manual before proceeding.) Finally, take a piece of wood and screw the two joining sections together in perfect alignment. The longer these support boards are, the more rigid the joint and alignment will stay. Continue installing the drain sections in a similar manner until the entire run has been completed.

MUD SLAB STAKING

Mud slabs can also be staked, but the slab must be at least 3" thick. Thicker mud slabs that are better, but they are not required. Make holes for the installation bars with a hammer drill before driving them into the slab. These holes should be very tight, but if they're oversized, fill the space with anchoring epoxy. The installation bars should resist the floatation exerted by concrete when placed.

The stiffness of the installation bars sometimes allows the x-angled alignment bars, mentioned in previous methods, to be omitted. If additional alignment is needed, attach a board across the tops of where two channels come together (see image.)

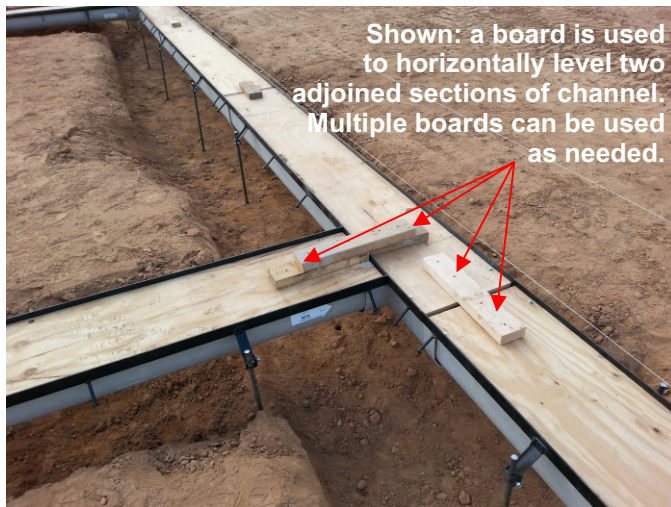

Another option is to drill an additional hole in the mud slab a few inches away from the installation bar, then drive another bar and use "tie wire" to pull the trench into alignment.

FORMED EDGE

For use when your installation will have concrete form work or there is existing pavement within a few feet of the drain.

Start by attaching lumber to the temporary plywood covers located on top of the trench drain. This will be used to suspend the drain sections. In most cases, the drain should be slightly lower than the forms.

Determine how far below the forms the drain should be and buy some plywood that is the proper thickness. Cut this wood into small blocks to place under the cross lumber (whaler.) If the span of the lumber will be fairly wide the cross boards may need to be turned on edge to make them strong enough so that they do not sag. If the boards can lay flat, simply use screws and drive them through the lumber and spacer plywood to the temporary plywood covers in the trench drain. If you cannot do this, then use long screws on an angle or tie wire to attach the cross boards in place. Tie the wood over the concrete anchors. Do not place the cross boards over the installation aides.

With this installation method, the elevation is controlled by the form work. Double check the form elevation for accuracy before continuing. Begin at the deep end of the trench and work toward the shallow end. Set the deepest piece of trench drain on top of the form work or existing pavement. Check that the flow arrow is pointing toward the outlet connection. Align the first trench section. Once the first piece is centered and the end is aligned to the ending location of the trench, secure it to the form work or pavement with screws or tapcons. Attach inlet and outlet pipes before continuing.

Set the remainder of the trench sections one at a time. Use the Dura Trench provided shop drawings to reference and verify that each labeled piece of trench drain is put in the correct location and check that all flow arrows are pointing toward the outlet location. If sealant of any kind is required apply it to the female bell before placing together. (For more detailed instructions on sealant installation see the “Sealing Joints” section later in this manual before proceeding.) Put an alignment string down one edge approximately 2-3” higher than the cross bracing and at the proper location. Begin setting trench sections at the deep end. Slide pieces tightly together. Using a square, line up the trench drain sections with the string line. Once each piece has been aligned, secure it to the form work or pavement with screws or tapcons. To perfectly align two sections of trench together, take some scraps of lumber and secure the two sections together with screws. This will make the trench more secure during the pour and hold the alignment precisely. Note that longer sections of wood keep alignment more secure. Continue in this manner to the end of the trench run.



To prevent the trench from floating during the concrete pour, Insert #4 installation bars and drive them into the ground. The bars need to penetrate the soil deep enough to be very difficult to remove. In clay and hard-compacted soils, this is usually about 18” to 24”. In sandy soils this can be 36” to 48”. These installation bars will help keep the trench from floating during concrete placement.

OVER MEMBRANE

When installing trench over a waterproofing membrane, take special care not to puncture the membrane. If the membrane is punctured in any way, the membrane may leak. For this reason, the typical installation bars must not be used.

The key with this type of installation is to hold the drain on the proper line and grade. Typically, drains that are over the top of a membrane are quite shallow and have fewer floatation forces so it does open up some options. We recommend reading the “Formed Edge” method of installation on page 7 of this guide as this method closely resembles what must be done. Take 2x4 lumber and screw them to the cover wood that is in the top of the



trench. Use stacked wood blocks on each side of these boards to hold the trench drain on the proper elevation. Wood blocks can be screwed to the spreader wood while the trench is held at the proper elevation.

Once the linear drain is on grade, it must be aligned and anchored. Straighten the linear drain by aligning to a string. Use long wood boards to screw over the top of the trench drain to fix the line and keep it straight. Additional bracing can be run from other objects protruding from the deck if required.

Once the alignment is perfect, the final step is to anchor the drain sections against movement. For this step, we recommend pouring mud-patty styled of concrete around the linear drain to secure it against movement. This is typically done at about 18-24" from the ends of the sections. By keeping the mud patties away from the joint it ensures a good back up seal on each joint. The concrete-patties should come up the sides and taper down each side. The concrete should not reach all the way to the top of the drain. It must be held down from the top so that sufficient concrete can encapsulate the load bearing frame. Once all sections are anchored with a concrete patty the spreader boards can be removed.

When it is time for placement of the concrete to finish grade, there are a few placement considerations. We recommend that the concrete be poured around the top of the drain evenly and on both immediate sides before the remainder of the concrete surround is placed. This focuses the placement crew on properly anchoring the drain and keeps the alignment true. **IMPORTANT: Do not let the placement crew use the drain as a pour stop by placing on one side only.** This can cause the drain to slide or roll over and will bring the linear drain out of alignment.

FIELD MODIFICATIONS

Unexpected obstacles can cause rerouting, or making adjustments to the Dura Trench system to fit your application. This section outlines some things that can be done to a Dura Trench linear drain system in the field. Field modifications should only be attempted by experienced construction workers with an eye for details. Purchase the SLPF (Standard) or SLCF (Vinyl Ester) Resin Kit from your sales representative or distributor prior to attempting these modifications.

URNS

- Set out all channels leading up to the turn.
- Measure from the end of the preceding trench frame to the turn location and mark this measurement on the top of the piece that must be cut on the outside of the turn.
- Mark half of the turn angle on both side of that mark making sure to mark down the sides of the drain with a square. Only square off the top frame or board because the bottom is sloping and will not give a proper cut line.



IMPORTANT: Double check your measurements and markings and that the cut is turned in the correct direction before proceeding.

WARNING: If you turn drain sections upside down on the ground, use caution that you do not mistakenly cut the drain in the wrong direction.

- Using a cut-off saw with a large abrasive blade, cut the drain.
- Install the first piece by using temporary stacked blocks to support the channel from underneath to ensure it remains on grade. Alternatively, a board can be fastened across the top and near the end to stake it up. Be sure to keep any of these boards away and back from the cut at least 8 inches to allow for connection of the next section of trench.
- Before installing the next piece, turn it in the proper direction then attach it to the other end of the turn by screwing a piece of wood across the corner at the top. This should help keep the drain from moving and keep the frames at the same elevation during the concrete placement.

IMPORTANT: Large gaps caused as a result of cutting must be covered with the fiberglass cloth and SLPF or SLCF resin kit purchased from your local Dura Trench sales representative or distributor prior to concrete encapsulation. Concrete intrusion into the channel can be prevented in small openings can be sealed by other means such as duct tape,

- Seal the inside and outside of the joint using your SLPF or SLCF kit. Additional instructions on using the sealant can be found on page 16 of this installation guide.
- After concrete encapsulation, check the channel for concrete that may have slipped through an opening. Remove this concrete immediately before proceeding.

TEE CONNECTIONS

CRITICAL: The tee-connections manufactured in our factory have an additional load beam under the frame at the tee intersection to properly support the system at the turn. This is impossible to replicated in the field. Due to the critical nature of that support load beam, field-fabricated tees should only be performed on narrow trenches that have little to no traffic loading on the grates at this location. If there is no alternative but to move forward then proceed. Otherwise, contact your local sales representative so that we may better assist you with the fabrication.



- Notching the adjoining trench frame back the amount of the frame overhang at the area where you are inserting the tee.
 - Mark with a square and cut it as square as possible. If the adjoining trench is the same depth as the one you are tying into you, will have to cope the bottom to match the profile of the trench you are connecting with.
 - Use a board to mount across the top of the connecting piece to hang the frames at the same height. Be sure it is very level and on the proper elevation.
- Once the location and height of frames has been verified, mark the perimeter of the abutting drain section.
 - Using an abrasive wheel cutter, cut the opening in the side of the drain that runs past the turn. **DO NOT** cut the frame of this drain section, only cut the drain body that is underneath the frame.

- ❑ Replace the abutting section to check for proper fit. Adjust as necessary so that there is not going to be a blockage of the adjoining trench section.
- ❑ Seal the inside and outside of the joint using your SLPF or SLCF kit. Additional instructions on using the sealant can be found on page 16 of this installation guide.
- ❑ After concrete encapsulation, check the channel for concrete that may have slipped through an opening. Remove this concrete immediately before proceeding.

INVERT (DEPTH) MODIFICATIONS

CRITICAL: Before making changes to the invert, please contact Eric'sons Manufacturing's technical staff and the Engineer of record for your project. Modifications to the invert can have unintended consequences. Our staff can help you determine the best course to proceed. By proceeding with the modification, the remaining sections of the run will be effected and must also be modified. This can take considerable effort to do properly and should be carefully considered when weighing the decision to make such changes. **DO NOT EVER remove the plywood from the frames.**

- ❑ Remove the trench body from the frames by removing rivets, screws, and prying off the frame (if it is glued.)
- ❑ Mark both the shallow and deep end for the new cut heights. Subtract out the frame height to the overall required invert.
- ❑ Use a chalk line or a straight edge to mark from one end to the other where to cut.
- ❑ Use grinder with a diamond wheel or a cutoff saw to cut each edge
- ❑ Put the modified section back on the frame that it was removed from.
- ❑ Use self drilling screws to re-attach the drain body to the frame.
- ❑ Continue this procedure for all remaining sections of channel.

TIP: DO NOT EVER REMOVE the plywood from the frames. The plywood holds the frames at the proper width during concrete encapsulation, to accept the grates

END PLATES

LOOSE PVC END PLATE(S) ARE USED FOR BOTH THE SHALLOW AND DEEP ENDS OF THE TRENCH.

NOTE: IF THE COMBINED TOTAL INVERT NUMBER BETWEEN THE SHALLOW AND END DEPTH EXCEEDS 19 INCHES, AN ADDITIONAL END-PLATE WILL BE NEEDED.

- ❑ Using a grinder with a diamond wheel or a cutoff saw, remove the bell-end from the trench drain. This is the section that protrudes past the end of the section of trench.
- ❑ Measure from the outside of the trench to the bottom of the wood cover board.
- ❑ Mark this depth by measuring from the inside of the flange on the closed end of the plate upward.

- Use a square and sharpie to mark a straight line across the plate.
- Cut the plate on this line using a jig saw, circular saw, grinder, cut off wheel, or other suitable tool.
- Attach the end plate to the shallow end of the trench with glue and/or screws. Glues that work well are urethane caulks, silicone sealants, liquid nails, etc. If using screws any short sheet metal or drywall screws will work effectively. If your screws are too long, after concreting they can be broken off from inside the trench or you can use a grinder trim flush.

Shown: End plate doubles as inlet/outlet when knocked out



INLET / OUTLET FITTINGS

Loose inlet / outlet fittings must be attached before the drain body, before installation.

- At the lowest point of the drain, measure and mark the location of the drain fitting on the bottom of the channel.
- Measure the drain body depth. If this measurement is shorter than the outlet fitting, measure the drain body depth from under the frame to the invert.
- Measure up from the bottom of the outlet fitting and mark this on the side of the fitting.
- Using a sawzall, grinder, or other tool that can make straight cuts cut the fitting off at this height so that the fitting will slide under the drain frame.



Shown: Universal bottom & side outlet accommodates 4" and 6" pipes

- Place the fitting on the bottom of the drain body and mark the outside edges. **DO NOT CUT HERE.** Instead, measure and mark for the cut *inside* these marks (typically about 1/2" inside these marks).
- Using a grinder with a diamond wheel or a cutoff saw, cut to remove the bottom of the drain up past any radius on the bottom of the drain body. For use of the side outlet, you will remove only the sidewall that you are coming out of and nothing on the bottom of the drain body.
- Using a hammer, gently tap around the edge of the hole of desired outlet location.

- Apply glue (urethane, silicone, or construction adhesive) around the perimeter of the cut that you made.
- Push the fitting on the drain channel.
- Use a couple of short screws to secure the fitting in place while the glue cures.

ATTACHING PIPES

WARNING: For end and side pipes, we strongly recommend at least 4” of concrete cover over any pipe connected to the trench drain in order to maintain the structural integrity of the concrete and the pipe.

- Using a diamond grit, or other aggressive hole saw, drill a hole in the body of the channel in the required location.
- Insert the pipe into the hole and seal with SLPF or SLCF kit. This kit is available through Eric’sons Dura Trench and includes glass fiber cloth and matching resin so that you can seal the connection. You can learn more about sealants on page 16 of this guide.

ATTACHING PIPES INSIDE UTILITY TRENCH (DTUT)

The Dura Trench DTUT utility trench systems utilize standard 1 5/8” channel struts which are cast into the walls of the trench channel. These channel struts have concrete anchors welded on the strut that are designed to handle up to 8” pipes and / or utilities inside the trench. Larger pipes can be accommodated upon request but requires special construction and engineering. The pipes can be attached using virtually any strut accessory on the market. Simply insert the hanger into the strut and turn just like any other strut.

SEALING JOINTS

Properly sealing linear drain joints ensure a watertight seal and provide protection against chemical attack. The various steps below are a general guide to sealing the joints, however, field conditions vary significantly and may alter the necessary procedures. **NOTE: For projects designed for storm watershed management, check with the Engineer of record for your project to see if a sealant is required. Many times, it is not.**

To continue, determine which body type that you are installing by locating the part number on the shop drawings provided by Dura Trench. The first few letters of the part number begin with “DT” and end with a series of letters and numbers. As a general rule, the joint sealant required should match the material properties of the environment. For example, if the floor has a chemical resistant epoxy flooring system the drain should have a sealant that is as chemical resistant. If the floor has no coatings or sealers a joint sealant may not be necessary.

SEALING CHANNEL BODIES DTPF / DTSP /DTCF / DTUT

With Gaskets

- Gaskets are self-sealing when properly installed and no other sealant will is required.
- Making sure the gaskets are attached to each end of the drain section, bring the two sections of drain bodies together. The resistance felt when pressing the two sections together is normal, as the gaskets seal by the rubber pressing firmly against the adjoining part.
- Press joint in place and attach boards across joint to keep sealed and aligned.

With SLUR

- Clean the bell-end receiving flange by wiping it with a cloth.
- Using a standard caulk gun, apply the sealant at each joint directly to the receiving bell, just before inserting the next section of channel. Continuously apply the sealant from top of the channel through the bottom and back to the top of the other side to ensure a positive seal.
- Immediately insert the joining piece of channel. The joint sealant is fairly flexible until cured.
- Perform all line and grade adjustments immediately after applying the sealant. After curing, use caution to minimize movement and any adjustments needed after curing, will break the seal.

With SLPP/CP

DuraTrench SLPP and SLCP are sealants that are the same material as the trench bodies. It is a polyester or vinyl ester paste material that is reinforced to prevent cracking. Note that it is a rigid material so once cured it is quite strong but brittle. This paste is also very useful in tooling joints after field fabrications have been made. All movements and adjustments with this material must be done before it cures. Instructions for use are below:

1. Find the components of the sealant kit. There will be a bucket of resin paste labeled part A and a smaller container of hardener labeled part B. Some kits include and require reinforcing mesh, which will be included with your kit if required. You will also need gloves, eye protection, putty knife, 100 grit sand paper, and acetone. These can all be purchased at your local hardware store.
2. To obtain a good seal, it is important to properly prepare the joint by cleaning and thoroughly drying it. Start by lightly sanding the two edges of the joint that will be touching each other with sand paper to give it a rough finish or some “tooth”. Once the sanding is complete, clean any debris off of the joint with a clean rag wetted with acetone or rubbing alcohol.
3. Before you mix the paste, if your kit came with glass fiber, cut the strips of fiberglass mat to the desired length to wrap the joint that is being sealed. The fiberglass mat is applied to the outside of the trench around the joints. The fiberglass mat can be applied later to the inside for additional strength and sealing if required, however, it will leave the trench slightly rough at the joints.
4. Make sure you are wearing your gloves and eye protection. Mix the resin paste (part A) with the hardener (part B – also known as the catalyzing agent). The resin paste and hardener should be mixed in small amounts as it will harden in approximately 5-10 minutes. **WARNING:** A large mass of resin can get very hot and catch on fire, or cause fires to surrounding materials. We recommend mixing the resin in small batches on paper plates (about 2 cups). The ratio of part B hardener is 2% to 98% part A resin paste. This ratio will give about 5-10 minutes to work with the resin before it begins to gel. (Assuming the temperature is above 55 degrees F. The curing process is temperature dependent and is slower at low temperatures and faster at higher temperatures.) Be sure to mix thoroughly by scraping sides and bottom while mixing. Do not throw catalyzed resin in the trash as it can heat up and start a fire. Place cooled resin in metal containers to dispose of unused, hardened material.
5. Spread some catalyzed resin paste on the female portion of the joint, and then mate the two pieces tightly together.
6. If you were supplied with fiberglass mat, smear some of the catalyzed resin paste on the outside of the joint. If you do not have fiberglass mat, the glass fibers were pre-mixed into the paste and you can skip to step 10.
7. In the uncured soft paste, lay the fiberglass mat over the seam and into the wet paste.

8. Smear an additional thin layer of resin paste over the fiberglass mat until the mat is wetted out. The mat is wetted out when all of the fibers are coated with resin paste.
9. Repeat if necessary to attain a proper seal.
10. Protect the joint from water for 4 hours minimum at standard room temperatures. Protect the joint from chemicals for 24 hours minimum at standard room temperatures. Longer cure time may be required at lower temperatures.
11. Clean up tools with Acetone (or rubbing alcohol) and a clean rag of cloth.

With SLPF/CF

Dura Trench SLPF and SLCF sealant kits are the same material as the trench bodies. It is a polyester or vinyl ester liquid resin material supplied with glass fiber mat. This material can be used to make water tight and structural connections between channel bodies. Note that it is a rigid material once cured. This material is very strong and has good flexural properties. This resin/fiber kit is useful in making fabrications, sealing joints, and all field repair work. All movement of this material must be done before it cures. Instructions for use are below:

1. Find the components of the sealant kit. There will be a bucket of liquid resin labeled part A and a smaller container of hardener labeled part B. You will also find a roll of glass fiber reinforcing mesh and chip brushes in the kit. You will also need gloves, eye protection, 100 grit sand paper, acetone or rubbing alcohol, paper bowls (or other mixing container), and possibly additional chip brushes. These can all be purchased at your local hardware store.
2. The most important step to a good seal is to properly prepare the joint. The joint must be dry. Start by lightly sanding the two edges of the joint that will be touching each other with sand paper to give it a rough finish or some "tooth". In some cases a flap disk on a grinder can also work well to prepare the joints. Once the sanding is complete, clean any debris off of the joint with a clean rag wetted with acetone or rubbing alcohol.
3. Cut the strips of fiberglass mat to the desired length to wrap the joint that is being sealed. It is best to do this before you mix the resin with hardener as you will have a limited amount of time after this step is complete. The fiberglass mat is applied to the outside of the trench around the joints. The fiberglass mat can be applied later to the inside for additional strength and sealing if required, however, it will leave the trench slightly rough at the joints.
4. Make sure you are wearing your gloves and eye protection. Get a bowl or other mixing container. Mix the liquid resin (part A) with the hardener (part B – also known as the catalyzing agent). The resin and hardener should be mixed in small amounts as it will harden in approximately 5-10 minutes or less. **WARNING:** A large mass of resin can get very hot and catch on fire, or cause fires to surrounding materials. We recommend mixing the resin in small batches in paper bowls (do not use Styrofoam). The ratio of part B hardener is 2% to 98% part A liquid resin. This ratio will give about 5-10 minutes to work with the resin before it begins to gel. (Assuming the temperature is above 55 degrees F. The curing process is temperature dependent and is slower at low temperatures and faster at higher temperatures.) Be sure to mix thoroughly by scraping sides and bottom while mixing. Do not throw catalyzed resin in the trash as it can heat up and start a fire. Place cooled resin in metal containers to dispose of unused, hardened material. Note any extra resin should be catalyzed and cooled for disposal in small batches.
5. If needed, place plastic, cardboard, or paper under the area where the resin will be used. This liquid resin will likely drip and protection is needed under the repair area.
6. Use a chip brush to apply catalyzed resin on the surfaces to be attached.
7. Apply the fiberglass mat to the liquid resin.
8. Brush additional catalyzed resin on the glass mat until it is completely wet with resin. The mat is wetted out when all of the fibers are coated with resin and become a clear color rather than the initial white color.

9. Repeat if necessary to attain a proper seal.
10. Protect the joint from water for 4 hours minimum at standard room temperatures. Protect the joint from chemicals for 24 hours minimum at standard room temperatures. Longer cure time may be required at lower temperatures.
11. Clean up area, brushes, and tools with Acetone (or rubbing alcohol) and a clean rag of cloth.

SEALING CHANNEL BODIES: DTSS

WITH BOLTED FLANGE & SEALANT

Some of the DuraTrench Stainless Steel drains come with a flange at the ends for connecting. This is typically used for sanitary, but not chemical, applications. If you have a system that will receive high concentrations of chemicals it is recommended that you weld the seams. If it is determined that a bolted flange joint is acceptable the following sealing method applies.

- Wipe the two facing flanges with a cleaning solvent such as acetone or rubbing alcohol and a clean rag.
- Apply a liberal bead of urethane sealant or epoxy sealant to the outside of the flange by placing the sealant on the outer edge of the flange it should seal the joint without protruding into the interior of the channel.
- Press the joints firmly together.
- Insert bolts and tighten.

WITH WELDING

Welding stainless steel joints gives the system maximum chemical resistance and durability. It is important to weld these joints prior to surrounding the system with concrete. Leave the plywood tops as they will aid in installation and have been left short in order to allow for safe welding.

- Turn the system upside down on a flat floor atop leveled saw horses.
- Align the trench sections and use clamps as necessary to hold the alignment.
- Use the appropriate welding process (typically TIG using a medium size filler rod.) Verify the grade of stainless steel before selecting a filler rod as DuraTrench DTSS systems are manufactured in both T304 and T316.
- After welding, it is necessary to clean and treat the joint so it does not rust. This can be done with a fine grit flap disk and/or a localized pickling paste (available at most welding supply stores).
- Before the channel is placed in the ground, cover all of the channel's tops and joints with short pieces of plywood to keep concrete from entering the trench.

SEALING CHANNEL BODIES: DTDCPF / DTDCCF

WARNING! Dual containment trenches must be completely sealed to perform their designed function. Each trench section will have two joints that must be meticulously sealed.

WARNING! DO NOT step or walk in the trench! While the trench bodies have been factory-sealed, stepping can cause a dynamic load significant enough to cause microscopic cracks in the rigid material that makes up the trench body. As a result, leaks will occur due to these microscopic cracks.

To continue, you will need the following:

- Dura Trench SLPP or SLCP kit** for the bell surfaces as the sections are being fitted together
- Dura Trench SLPF or SLCF kit** for the outside of the outer trench and the inside of the inner trench
- When joining the sections of double containment trench, use the SLPP or SLCP kit to seal both inside and outside of each receiving bell. Refer to page 15 for detailed instructions regarding how to use the SLPP and SLCP kits. **Do NOT proceed if you do not have the appropriate kit.** Once the sections of trench have been joined together and the bells have been completely sealed, proceed to the next step.
- Seal the outside of the outer trench joint using the SLPF or SLCF kit. **DO NOT** proceed if you do not have the appropriate kit. Refer to page 16 for detailed instructions regarding how to use the SLPF and SLCF kits.
- Seal the inside of the inner trench using the SLPF or SLCF kit. **DO NOT** proceed if you do not have the appropriate kit. Refer to page 16 for detailed instructions regarding how to use the SLPF and SLCF kits.

WATERPROOFING & MEMBRANES

TRENCH & FLOOR DRAIN FLASHING COLLARS

Trench drains containing a flashing collar along the entire length of the drain must be carefully installed, as the drain becomes part of the waterproofing system by allowing water that reaches the waterproofing membrane, to escape. These systems require the lower portion of the drain to be water tight and it should be tested to ensure this. The upper portion must mount to the lower portion, but should allow water to weep into the lower portion of the drain.

The lower portion of the drain is installed and sealed water-tight in the structural slab by first utilizing any of the afore mentioned installation methods, followed by installing the membrane. These membranes can be made of a rubber/vinyl material, or can be liquid-based and applied like paint. The

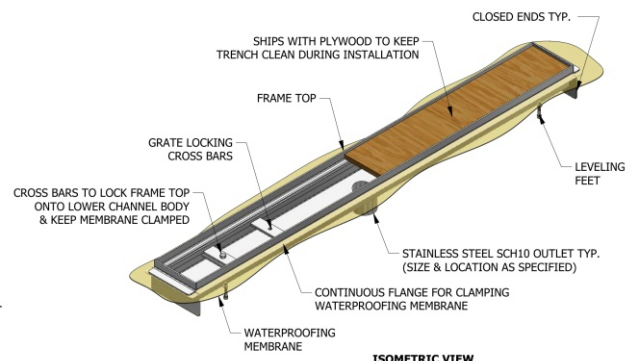

membrane must be sealed to the lower drain body. The flashing collar on the drain should be cleaned with a solvent such as acetone or rubbing alcohol and a clean rag. Once clean, apply a liquid-based membrane to seal to the flashing collar. Sheet membranes should have a bead of sealant applied to the clamping collar. After “clamping” the collar, then insert the bolt over it, to ensure the membrane does not pull away from the drain.

Once the membrane is installed, perform a flood test. This will verify that the seal between the clamping collar and the membrane is correct. This can be done by running water across all areas of the drain for at least 15 minutes to see if water begins leaking to the lower level. If water is leaking below pull up the membrane in this area and correct the seal.

The upper portion of the linear drain can be installed after successful membrane testing. Be careful to protect the membrane from punctures during the remaining installation process. The top portion of the drain bolts to the lower portion of the drain at the cross bar locations. TIP: To keep everything in perfect alignment, loosely bolt the drain in place and then go back after with a string line to tighten in perfect alignment. **Note:** If the waterproofing membrane has some variable thickness, it is acceptable to shim between the membrane and upper drain section to get a perfect finish grade. If the shims get very large it may become necessary to place a filter fabric with construction adhesive in order to keep concrete, or paver sand, from exiting through this joint.

OUTLET CLAMPING COLLAR

Outlet clamping collars are installed first in the structural slab. Pay special attention to the layout of these outlets as failure to do so will result in them not being properly aligned and *cannot* be adjusted later. It's critical that outlets be placed with no more than 1/4" deviation in any direction. Before proceeding, verify with a string line, transit, or other device, to ensure precise placement.

The next step is to have the waterproofing contractor install the waterproofing membrane. The membrane should be sealed to the clamping collar. Clean the clamping collar with acetone or rubbing alcohol and a clean rag. Liquid-based membranes can be applied directly to the clamping collar. Sheet membranes should have a bead of sealant applied to the clamping collar before being applied. When using a sheet membrane screw the clamping collar in place at this time. Leave the clamping collar off for now if using a liquid applied membrane.

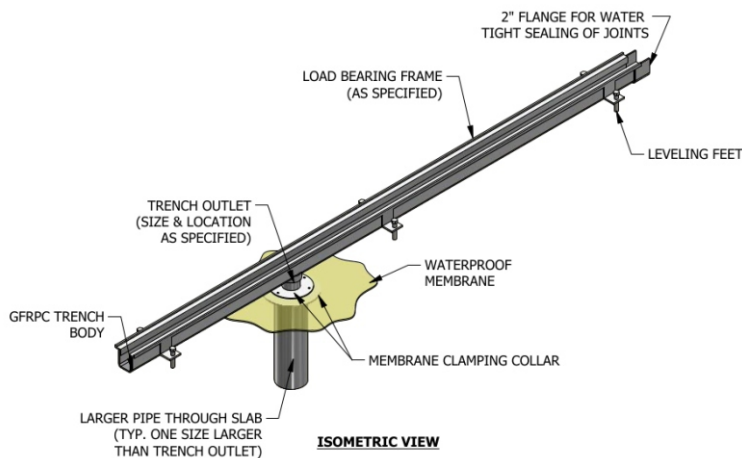

Perform a water test to verify the membrane to drain connection by running water for at least 15 minutes at each penetration. Inspect below for any signs of water. If any water is found to

get behind the membrane the membrane must be removed and re-installed at this time.

The linear drain system is ready for installation with any of the afore mentioned installation methods, as long as the membrane is not damaged. Note: Because the linear drain is entirely above the membrane, joint sealing is not critical in this type of application. When inserting the outlet pipe into

the hole, loosen the screws on the membrane clamping collar. This will allow the clamping collar to slide. Leave the screws loose until the final alignment of the system is complete. Once proper alignment is achieved, re-tighten these screws. Now place a geotextile filter fabric around the outlet pipe connection and place gravel around the bottom of the clamping collar. This will allow the membrane to weep properly without any foreign material entering the drain.

BEST PRACTICES WHEN NO MEMBRANE EXISTS

Waterproofing membranes are the best measure to ensure leaks don't propagate in the floor and weep to lower levels. However, using them are not always possible and although we do not recommend this type of construction for wet environments, it's often specified by designers to keep costs low. The following methods are to only be used when a proper waterproofing membrane is not possible.

FLOOR & LINEAR DRAINS - New Construction Concrete Slab

A simple elevated slab has only a single layer of concrete without a waterproofing membrane. This type of construction can be problematic for wet areas but it is possible to achieve a dry environment so long that it is properly constructed. In this application, a drain itself is outfitted with weep holes and a waterproofing collar. In many cases, the top of the slab is treated with a waterproofing material such as a resinous flooring system to stop the migration of water through cracks and porous concrete.

In continuing this type of construction, the drain is placed in the concrete-slab pour and the drain will have a waterproofing collar that is roughly at mid depth of the slab. A swell stop material (similar to Cetco Rx102) is placed just below the waterproofing collar to stop water migration around the perimeter of the drain. Note that care should be taken to ensure the swell stop material is not too close to the bottom of the slab. The swelling pressure of the swell stop type waterproofing can cause the concrete to spall due to internal pressure and tensile forces. The distance from the concrete surface to the swell stop varies by product used. For Cetco Rx102 a 2" minimum is required.



Concrete is porous, will expand and contract, and crack. All of these will allow water through the slab. To prevent this, proper treatment of the slab above is a must. Ideally, penetrations in the slab should be at high points in the slab to minimize water in those locations. If that is not possible, it is a good idea to have a waterproofing flange and swell stop material applied so that the cracks will not leak. Finally, the slab must be sealed at all points. All joints that move must be treated with a sealant and the slab itself must be waterproofed. These techniques are out of the scope of this document but must be considered for an effective elevated deck.

FLOOR & LINEAR DRAIN INSTALLATION FOR EXISTING CONCRETE SLAB RETROFIT

When a second floor drain is retrofit into this type of construction, the drain and the perimeter of the cut should be waterproofed with the swell stop material at roughly mid grade. The drain should still have weep holes.



Start by drilling a small hole where the drain should be located. Locate the hole below the slab to ensure the location will allow for the p-trap, piping, and that it will not interfere with any structural beams or equipment below. Never remove any portion of a structural member to install a drain.

Assuming the location is appropriate, the slab can be cut. There will be water running at this location at the end of the cut. Be sure to protect sensitive equipment below this location. Also, prepare for a heavy slab of concrete to fall below. A proper support needs to be in place to catch this slab of concrete. A man lift is often elevated to the bottom of the slab so that the slab can be safely lowered after cutting.

The drain must be properly doweled to the existing structural slab to ensure movement of the drain does not happen. This is best accomplished by doweling old to new. A simple reinforcing cage around the drain spreads the load to ensure pressure is

distributed on all dowels evenly. Dowels should be epoxied with an epoxy anchoring material similar to Hilti HIT500.

The ceiling of the floor below must be formed and braced to take the weight of the fresh concrete until it can properly set. DO NOT remove form work until after the concrete has properly cured (preferably 7 days but will vary with concrete mix design.) Also, the newly constructed drains should not receive vehicular or forklift traffic until the concrete has reached sufficient strength. Typically this is 2 weeks for standard concrete but can be sped up with proper mix design. Note that the reinforcing bar size should be determined by the load. Typically, on a second floor application only smaller forklifts are utilized and a #4 reinforcing bar is sufficient. Consult a structural engineer if you are unsure of the reinforcing that should be used.

LEAK TESTING

LEAK TESTING FLOOR AND LINEAR DRAINS SHOULD NOT BE COMPARED TO LEAK-TESTING OTHER PLUMBING SYSTEMS. FLOOR AND LINEAR DRAINS ARE MEANT TO CONVEY WATER TO THE PLUMBING SYSTEM AND OFTEN DO NOT REQUIRED TO BE WATER TIGHT THEMSELVES. DUE TO THE OPENING IN THE TOP, THESE SYSTEMS CANNOT BE PRESSURE TESTED. A SIMPLE FILL, WAIT, AND WATCH METHOD IS ALL

THAT IS NEEDED AND AVAILABLE TO THE INSTALLER. IN MOST CASES (IF THERE IS NO COATING ON THE FLOOR) THE CONCRETE THAT SURROUNDS THE DRAIN CAN BE USED TO SEAL THE DRAIN. IF THERE IS A WATERPROOF COATING ON THE SURROUNDING SLAB THE DRAIN SHOULD BE TESTED TO ENSURE IT IS WATER TIGHT. FOR THESE CASES, FOLLOW THE PROCEDURES BELOW FOR EITHER SINGLE OR DOUBLE WALL DRAIN SYSTEMS. **NOTE: DURA TRENCH DRAINS ARE NOT WATER TIGHT FROM THE FACTORY.**

LEAK TESTING SINGLE WALL DRAINS

Locate each inlet and outlet pipe and cut a hole in the plywood to access the inlet and outlet pipes. **DO NOT EVER remove the plywood completely, until you are ready to install the covers!** This will cause the frames to come out of alignment. Using commercially available plugs, plug each of the inlet and outlet pipes. Any type of commercially available plug can work and if they're not available, you can use any method, so long as it slows the water enough to check for leaks.

After all the inlet and outlet pipes have been plugged, flood the trench with water. Fill the trench until the **water reaches just below the locking ledge (bottom of the frame.)** Note that these systems are not designed to be water-tight above this point. Once the trench has been filled, wait at least 15 minutes, per IPC specification 312.2. If no leaks are present the system is water-tight. It is also important to note that after the concrete placement and it cures, the drains will be even more secure and water-tight.

If the water-test shows a leak, mark it for repair. Remove the test plugs to evacuate the water. Allow the area to dry completely before proceeding. If the body is wet, the repair will not work. If needed, use a heat gun to expedite drying time. Use an appropriate sealant to seal the leaks and repeat the leak-test procedure, waiting 15 minutes to observe the results.

The types of sealant that can be used vary by application. For systems designed to move water, a standard urethane, silicone, or bituminous waterproofing material can be used. However, if the channel drain is designed for chemical loading, then you must use a resin designed for it, such as polyester, vinyl ester, or epoxy. Contact your DuraTrench representative if you need help selecting the proper material.

LEAK TESTING DOUBLE (DUAL) CONTAINMENT DRAINS (DTDCPF & DTDCCF)

Locate any inlet and outlet pipes coming from the secondary liner (if they exist.) These pipes should have a valve on them that can be closed for this test. If they do not, you will need to install a valve or cap downstream to close to the drain. **DO NOT EVER remove the plywood on top of the trench until you are ready to install the covers!**

After plugging all of the inlet and outlet pipes, use the inspection ports to flood the outer trench with water to **just below the locking ledge (bottom of the frame)**. NOTE: DTDCPF systems are not designed to be water-tight above this point. If your project requires the drains to be water-tight above this point, apply an appropriate sealant seal that connection. If this is done, beware to keep sealant minimal so that it does not impact the bearing capacity of the frame at the top of the trench. Improper sealing procedures in this area can void the warranty. Once the secondary trench has been filled wait at least 15 minutes, per IPC specification 312.2. At this time, only inspect the outside for leaks. If no leaks are present the system is water-tight. It is also important to note that after the concrete placement the secondary containment drains will be even more secure and water tight.

If the water-test shows a leak, mark it for repair. Remove the test plugs or turn the valve to evacuate the water. Allow the area to dry completely before proceeding. If the body is wet, the repair will not work. If needed, use a heat gun to expedite drying time. Use an appropriate sealant to seal the leaks and repeat the leak-test procedure, waiting 15 minutes to observe the results, per IPC specification 312.2. The types of sealant that can be used vary by application. For systems designed to move water, standard urethane, silicone, or bituminous waterproofing material can be used. However, if the channel drain is designed for chemical loading, then you must use a resin designed for it, such as polyester, vinyl ester, or epoxy. Contact your Dura Trench representative if you need help selecting the proper material.

Water-test the interior channel after the concrete placement. **DO NOT EVER** remove the plugs or valves used to seal off the external drain body. Leave them in place with proper access. Valves must remain accessible after the concrete surround is poured. Do not proceed until after concrete placement.

After the concrete encapsulation has cured, remove the plywood covers and plug the outlet, as well as the secondary drain inlet and outlet pipes, to test the interior drain. Now, flood the outer trench through the inspection port with water, stopping just below the frame of the inside trench. Field measurements will be required for accuracy.

Once the trench is filled with water, any leaks will present themselves as water seeping or flowing into the inner trench from the outer liner. Mark the problem areas for repair. Drain the water and thoroughly dry the drain. Allow the area to dry completely before proceeding. If the body is wet, the repair will not work. If needed, use a heat gun to expedite drying time. Use an appropriate sealant to seal the leaks and repeat the leak-test procedure, waiting 15 minutes to observe the results, per IPC specification 312.2. **After making any necessary repairs, cover the channels immediately with the grates, solid covers, or temporary plywood covers. Failure to do so will allow for construction personnel to walk on and damage the bare channels by creating stress fractures within the body and on the joints of the channel.**

QUALITY CONTROL CHECK

A proper quality control program can help eliminate any unwanted and costly rework of the drain system. It is very important to do a final check before concrete is poured and have on site quality control during the concrete placement. The drain should be checked for the following issues:

- Elevation - verify along the trench that the elevation is within the tolerances. Also verify that the bench mark is correct. This is the last time you can get this right without significant cost.
- Line - use a transit or string to verify that the drain is straight.
- Rigidity - push on the drain at multiple locations along the length of the drain. The drain should not be easy to move or wiggle. If the drain moves easily it has not been braced sufficiently and it will be crooked after the concrete placement. Add more bracing at this time.
- Flow - verify that all the flow arrows are pointing toward the outlet pipes and are in the correct number per the shop drawings. This will tell you if water will flow inside the drain as designed.
- Connections - verify that all pipes are connected both coming in and going out.
- Holes - look for any openings that may let concrete into the system. Pay special attention to any areas that have been field fabricated. Also look at the plywood tops to make sure there are no large openings. Large volumes of concrete inside the system can be really difficult to remove later.
- Floatation - verify the trenches are secured down against floatation. This can include checking the

length of the installation legs to ensure they penetrate the earth far enough to resist the floatation, checking cross bracing and edge forms for resistance, checking tapcons, etc. Pull on the trench edges in a vertical manner to see if it pulls up easily. If it does add more vertical resistance before pouring.

CONCRETE SURROUND PLACEMENT

MIX DESIGN

The concrete mix design plays a vital role in the finished Dura Trench system. If the mix is too fluid, it will be difficult to maintain a slope into the drain. If the mix is too stiff, it will not flow properly around the reinforcing and drain body. Often times, you will need to tackle this problem with the engineer of record well before the construction takes place.

The best mixes for linear drainage construction have a slump between 5 and 6. Linear drains traditionally have a number of obstructions and are better poured with smaller aggregate. We find aggregate in the 3/4" size or less is most favorable. Additionally, it's often necessary to use plasticizers in the mix so that the desired slump can be obtained without altering the engineer's requirement for water to cement ratio.

Depending on the time of the year, it may also require the use of retarders or accelerators. During periods of colder weather you can use accelerators to speed the cure. A faster curing concrete (especially on the first lift,) can significantly reduce the vertical floatation forces. During warmer weather a retarder may be needed to keep from getting cold joints and to give finishers the proper time to perform finishing operations.

VIBRATION

No matter the concrete mix, proper consolidation of the concrete is essential to the strength and durability of your Dura Trench linear drain system. Concrete is typically vibrated with a pencil vibrator to remove any air pockets. The smaller the head and the stiffer the mix, the closer the vibrator insertion spacing should be. Typically the vibrator is inserted every 1-2 feet, however, this will vary. Choose a systematic approach by watching specific points on the drain and not deviating from them. Pay special attention to the last lift of concrete. This lift is often neglected because the finishers are in close proximity and it tends to make more mess. Remember that all the traffic loading is exerted on the drain frame. If this frame is not surrounded with concrete it will not properly transfer the load. It is imperative that the concrete be vibrated to remove air pockets under the lip of the frame. DO NOT over vibrate the concrete.

ANCHORING POUR

An anchor pour is a method of pouring concrete in two installments, that can be used to "anchor" the linear channel drain by locking the alignment and stopping floatation. Doing this ensures quality functionality and appearance. Your project's engineer may argue against this method citing concerns about the two separate concrete pours acting as one. While there can be issues with two independent pours, we have seen far more problems caused by pouring trenches in a single pour. Since the installation bars act as a dowel between the two pours, DuraTrench strongly recommends anchor-pouring concrete up to just past the radius on the bottom of the trench. Leave the bottom pour "rough" to give the second pour some extra stability with significant mechanical locking power.

FLOATATION

Floatation of a linear drain is one of the biggest problems any contractor will face during the installation process. Properly staking the trench to the ground is a very good way to resist the vertical

forces that are exerted when pouring the concrete. Drains can also be tied to dowel bars, form-work, or any other rigid embed. Weight can also be applied to the trench to resist these forces, but it will take 150 lbs of weight per cubic foot of drain.

An anchor-pour will stop the floatation (discussed above.) If an anchor pour is not allowed on your project, we recommend proper truck spacing. In other words, you will want to time the trucks so that after you pour the bottom it is starting to get tight before you pour the next lift. Do not space so far that you get a cold joint, but space far enough to reduce the floatation forces. As it hardens, concrete begins to support its own weight. When the bottom concrete pour is self-supporting the floatation forces no longer exist. In the summer months this can be as short as 30-45 minutes. In the winter months this can be as long as 60-90 minutes.

FINAL POUR

The concrete should be placed evenly on both sides of the drain so that the alignment is not compromised. The best way to do this is to split a piece of pipe or build a triangle shaped sled over the drain. The truck can pour directly on the center and the concrete will flow evenly on both sides with minimal concrete on top of the drain. **Watch the vibrator to ensure the insertion spacing is properly maintained.**

Clean all concrete off of the top of the drain as you pour. This will make cleaning of the top, removal of the plywood, and insertion of the grates easier in latter steps.

FINISHING

When installing the final concrete pour, be sure all the finishers know how the end product should look. The drain should have slope from the form edge to the drain. This means that each side must be struck, floated, and finished independently.

Check the elevation of the concrete at the outer edge and next to the frame. The concrete should be finished to the top of the form or existing slab edge. The trench frame should be 1/8" below the surface of the concrete. Do not finish the concrete below this edge because it will cause water to pool behind the drain frame. It is also not recommended to tool the edge next to the trench frame. Tooling this edge can cause water to pool, subjecting it to freeze / thaw process as well as water infiltration. If you are brooming the surface, we recommend brooming from the edge of the form toward the drain. This allows grooves to flow into the drain keeping the surface dry and increases slip resistance.

DURA TRENCH FORMING SYSTEMS - FORM REMOVAL

DTTF

The forms on the Dura Trench DTTF system are disposable and made to be easily removable. First remove the plywood tops. The forms are split down the center. With some widths and profiles, the forms are connected using fasteners. Located just below the grate seat area, remove the fasteners (if applicable) in the bottom of the trench and take the forms out in two pieces using a small pry bar to pry the forms from the concrete. Pull the forms straight out the top.

Once the forms are removed, discard them. The concrete that was poured behind the forms is now expo. If there are any air pockets or voids they will need to be repaired. The repair procedure will vary depending on the loading and concrete repair materials that are approved for the project. Consult the engineer of record for proper materials and procedures.

DTSF

The DuraTrench DTSF trench forming system uses a set of re-useable steel forms. To remove these forms, unbolt the top plate from the frame and the system underneath. Remove all covers so that you can access the trench forms beneath. Now, remove the fasteners that hold the sections together. In some cases, especially if you are “gang forming,” this will only be every other section or more. Do not remove the fasteners from joints that need to remain together. Simply hook the lifting eyes with your lifting device (crane, excavator, forklift, etc.) and pull up vertically in the center. The forms will collapse and demold easily.

Once the forms are removed, they should be scraped clean and more form release applied to protect the steel. The concrete can now be inspected for imperfections. If there are any air pockets or voids they will need to be repaired. The repair procedure will vary depending on the loading and concrete repair materials that are approved for the project. Consult the engineer of record for proper materials and procedures.

INSTALLING GRATES / SOLID COVERS

REMOVING THE TEMPORARY PLYWOOD COVER

Remove the temporary plywood only when you are ready to begin installing the grates or solid covers. This can be done by removing any fasteners and then prying the wood out of the frame. The wood may get a little stuck with concrete slurry but they should pop out relatively easy. If they are not coming out easily, search for any fasteners that were missed. This wood can be re-used on the job site or discarded at this time.

CLEANING THE CHANNEL’S INTERIOR

Before installation of the grates the trench should be cleaned thoroughly and inspected. Any concrete that got into the trench needs to be removed. The drain flow line should be smooth and without debris. Use a shovel, broom, hammer, scraper, etc. to get this area cleaned. While cleaning be sure to clean the frame paying particular attention to the grate seat area. This ledge often has some concrete slurry that should be easily removed due to the slick nature of the frames. **DO NOT** sweep debris into the drain pipe. Move the material in into piles and then scoop or vacuum out of the drain.

GRATE SPACING

Grates should be installed with 1/8inch spacing between each grate. Ideally, grates will not span across a frame joint. For example, an 8-foot long rail would have four (4) quantity - 2 foot long grates on top. The next set of grates would be aligned with the next set of frames. This is important because if the installer did not get all the frames on exactly the same elevation it is possible that the grates will rock if they span over a frame joint. Additionally, failure to space the grates at the correct width will result in a shortage, or gap, of grates over extensive run of channel.

CUTTING GRATES

It is often necessary to cut a grate to fit the length of the trench but before you start marking and cutting, consider the location of the locking devices. After the grate is cut, ideally there should be a locking device on every grate, including short cut pieces. Further more, the lock should be centered to the grate, if possible. Try to plan short cut pieces of grating so that they go in areas with little to no traffic. The smaller the piece, the more likely they are to jump out of the trench in traffic.

Now that you have considered the cut location on the grate, measure the remaining opening.

Mark the grate where you intend to cut, while keeping the locking locations on the grate. **TIP: Orient the grate to where the cut falls on the slot in the grate. Doing this allows for faster cutting and better support to maintain the load-bearing weight. Short protrusions past the support ribs on the back of the grate, generally do not pose a problem but if the protrusions get too long without support, they have a tendency to break off in time.**

Now that the cut location is marked, you are ready to cut. Choose a suitable tool that is intended for your grate material. For plastic grates, a sawzall, circular saw, or other toothed saw works well. For metal grates, an abrasive blade is typically best (this might include a grinder or cut-off saw.) Simply make the cut and then evaluate it for burrs that could possibly cut shoes or bare feet. This can often be remedied by lightly sanding the cut-surface. At this time, touch up any coatings or paints to prevent premature rusting and corrosion (if applicable.) To prevent the rusting of stainless steel grates caused by its exposure to carbon, passivate the cut ends with a pickling paste or in a pinch, you can sand the ends to remove exposed carbon.

GRATE TOGGLE LOCKS

To install toggle locks, you will first turn the grate on their side. Insert the bolt through the hole in the center of the grate. Take the toggle in the other hand and get it started on the bolt. Next lay the grate into the trench frame. Using a nut driver begin to tighten the bolt. The toggle will rotate up under the locking ledge and then begin to tighten. Do not over tighten these locking devices. Over tightening the bolts will cause the toggle bar to bend. Bent toggle bars will have reduced holding capacity.

GRATE SADDLE CLIPS

Saddle clips are most often used on bar grates and on fiberglass grates. There are two styles of saddle clip locks. The first uses a large bolt, saddle clip, and toggle. This style is installed just like the locking toggle method above except that the saddle clip is inserted in the top of the grate in order to create a hole for the bolt.

The second kind of saddle clip lock uses self drilling screws. If your system came with self drilling screws then lay the grates into the trench. Now align the saddle clips over the locking ledge. Insert and drive the self drilling screw through the hole and into the locking ledge below. Do this at all four corners. For this style of grating it is recommended that you place all grates and ensure proper spacing before you drive the screws home.

GRATE 4-CORNER BOLTING

Grates that require bolting at all four corners come in two styles. The first type uses a large 1/2" diameter bolt that gets bolted directly into the frame. If you have this system you will install the grates in the trench. Line up the slots in the grate with the holes in the frame. Blow or vacuum any debris that may be in the bolt hole out. Then screw the bolt into the hole until the grate is tight and secure. Do this at all four corners.

The other type of bolted grate uses a self drilling screw. Simply install the grates and drive the self drilling screws through the holes in the grates. The screw will line up with the locking ledge where it can be driven until it tightly holds the grates in place. Repeat for all four corners. For this style of grating it is recommended that you place all grates and ensure proper spacing before you drive the screws home.

CLIPLOCK™

IMPORTANT: Attach the ClipLocks™ to all of the grates before securing the grates to the trench drain. Once the grates with attached ClipLocks™ are pressed into place into the trench, the grate cannot be moved without destroying the drive screw pins. Dry-run the layout until you are

confident they are in the correct position. This is especially important with radius'd (curved) grates.

- Find the holes or slotted areas, located on the length side of the grate.
- If your system calls for 2 clips per grate use the two holes on either side in the center. If your system calls for 4 clips per grate use the 2nd hole from the end of each grate end. If you system calls for 6 clips per grate use the same holes but add clips to the 2 center holes also.
- Align the ClipLock™ with the attachment location on the bottom of the grate. A hole in the top of the clip will align with a hole in the bottom of the grate.
- Hammer the provided drive screw through the hole in the clip to attach the ClipLock to the grate.
- Place the grate in the frame, aligned with the locking notches.
- After verifying the grate is in the correct placement, press the grate into plate.
- To remove the grates you will insert a flat tool behind the clips and pry out on all clips on one side and rotate out of the locking ledge.

SEALING SOLID COVERS

Some solid covers are required to have a gasket to minimize water infiltration. To properly install the gaskets you will first need to clean the frames of all latent dirt, oil, etc. Scrape any concrete and wipe with a rubbing alcohol. Immediately after rubbing the surface with alcohol, peel and stick the gasket material down the length of the frame.

Next, install the first grate and fasten in place with the provided locks. If desired, a small amount of urethane or silicone sealant can be used just under the bolt head. Wipe the overlap ledge with the rubbing alcohol and a clean rag of cloth. Apply the peel and stick gasket material across the top of the overlap ledge and extend over each end to the gasket on the frame. Cut it to make a tight fit on both ends. Repeat this process until all grates are installed.

If the system is required to be 100% water tight, a sealant will also need to be applied. Apply urethane caulk down the joint on both edges, and between each grate, to further seal the covers in place. NOTE: the surfaces need to be clean and the caulk does not need to fully fill the gap. The caulk only needs to fill the top 1/4" of the gap between grates and frames.

In 2020, Eric'sons Manufacturing introduced the Dura Trench Rapid Program answering customer demand for A) faster lead-time for receiving materials and B) lower material costs. This program utilizes our standard trench drain parts to allow a customer to build a trench drainage system that meets those criteria. In this program, our drains will arrive onsite in 8' sections and with loose outlets and loose end-plates. In cases where two neutral sections of trench must be joined, joint connectors will be included. Before installing, you will need to attach these pieces in accordance with your drainage layout.

RAPID DTPF4 Parts Worksheet

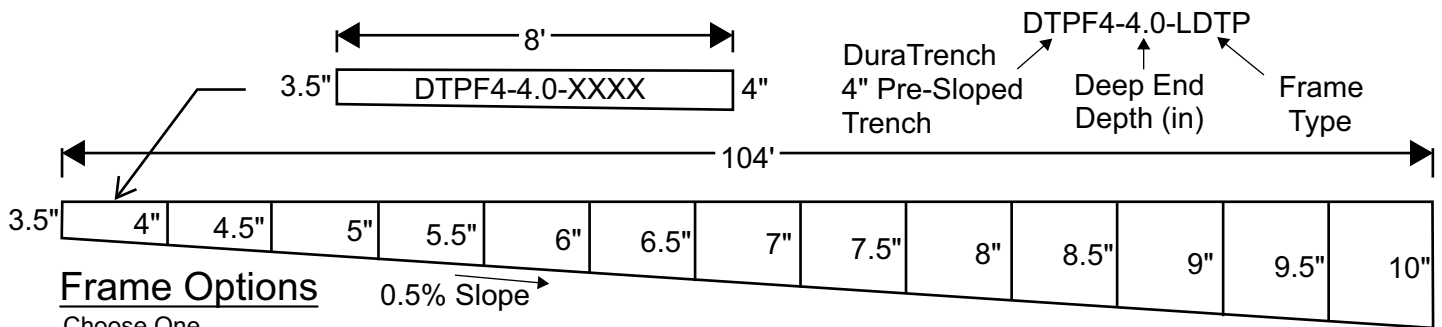

Frame Options

Choose One

- LDTP (Light Duty Thermoplastic Frame, DIN A Loading)
- HDBP (Heavy Duty Black Powder Coated Steel, DIN D Loading or DIN E w/ 5000 psi Concrete)
- EFBP4 - End Frames for Heavy Duty Black Powder Coated Trench Drain Runs
2x suggested per run, for each end, when utilizing -HDBP frames

Channel Quantities

Pre-Sloped (0.5%) or Neutral (0%) Channels, length as noted

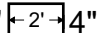
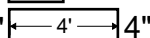
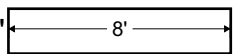
- DTPF4-4.0- (DuraTrench 4" wide precast channel, 8' long, 3.5" to 4.0" depth)
- DTPF4-4.0N-2- (DuraTrench 4" wide precast channel, 2' long, 4.0" depth) 
- DTPF4-4.0N-4- (DuraTrench 4" wide precast channel, 4' long, 4.0" depth) 
- DTPF4-4.5- (DuraTrench 4" wide precast channel, 8' long, 4.0" to 4.5" depth)
- DTPF4-5.0- (DuraTrench 4" wide precast channel, 8' long, 4.5" to 5.0" depth)
- DTPF4-5.0N- (DuraTrench 4" wide precast channel, 8' long, 5.0" depth) 
- DTPF4-5.5- (DuraTrench 4" wide precast channel, 8' long, 5.0" to 5.5" depth)
- DTPF4-6.0- (DuraTrench 4" wide precast channel, 8' long, 5.5" to 6.0" depth)
- DTPF4-6.5- (DuraTrench 4" wide precast channel, 8' long, 6.0" to 6.5" depth)
- DTPF4-7.0- (DuraTrench 4" wide precast channel, 8' long, 6.5" to 7.0" depth)
- DTPF4-7.5- (DuraTrench 4" wide precast channel, 8' long, 7.0" to 7.5" depth)
- DTPF4-8.0- (DuraTrench 4" wide precast channel, 8' long, 7.5" to 8.0" depth)
- DTPF4-8.5- (DuraTrench 4" wide precast channel, 8' long, 8.0" to 8.5" depth)
- DTPF4-9.0- (DuraTrench 4" wide precast channel, 8' long, 8.5" to 9.0" depth)
- DTPF4-9.5- (DuraTrench 4" wide precast channel, 8' long, 9.0" to 9.5" depth)
- DTPF4-10.0- (DuraTrench 4" wide precast channel, 8' long, 9.5" to 10.0" depth)

Total Footage of Trench Channels

LF

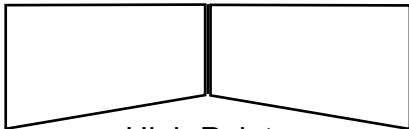

High Points

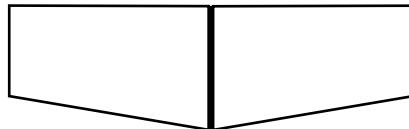

Low Points

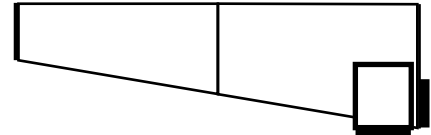

Outlet Plates

One UEP4 minimum per run of trench
Two UEP4 per run if UBO4 used

UEP4 - Universal End Outlet

UBO4 - Universal Bottom Outlet

End outlet to be used on channel 8" or deeper to allow 4" conc cover over 4" pipe

Joint Connectors

One needed for each high or low point

JC4 - Joint Connector for 4" wide trench

At low point, Contractor to cut female ends off

Grates and Locks

All 05 grates are 5" wide x 24" long x 0.75" thick. Suggested # of: Trench Grates: CB 5" Grates:

05B24DI - Ductile Iron Slotted Grate - E-Coated Black

05C24DI - ADA/Heel-Proof Compliant Ductile Iron Longitudinally Slotted - E-Coated Black

05C24TG - Gray Plastic ADA/Heel-Proof Compliant Longitudinally Slotted

05D24GSB - 12 Gauge Galvanized Steel Stamped Slotted Grate

05D24SSB - 12 Gauge Stainless Steel Stamped Slotted Grate

GLZN4 - Grate Locks including bolt, washer as required, and 4" locking bar for 5" Grates

GLSS4 - Stainless Steel Grate Locks incl bolt, washer as req and 4" locking bar for 5" Grates

Locks are not designed for traffic turning, braking, or longitudinal travel exceeding 20mph.

Catch Basins, Grates and Locks

DTCBPF4-D24-HDBP - 4"W x 24"L x 24"D catch basin with HDBP Frame

DTCBPF4-D24-LDTG - 4"W x 24"L x 24"D catch basin with LDTG Frame

DTCBPF10-D24-HDBP - 10"W x 24"L x 24"D catch basin with HDBP Frame

DTCBPF24-D24-HDBP - 24"W x 24"L x 24"D catch basin with HDBP Frame

12B24DI - Ductile Iron Slotted Grate - E-Coated Black - 12"W x 24"L x 1.5"T

12C24DI - ADA/Heel-Proof Compliant Ductile Iron Longitudinally Slotted - 12"W x 24"L x 1.5"T

26B24DI - Ductile Iron Slotted Grate - E-Coated Black - 26"W x 24"L x 1.5"T

GLZN10 - Grate Lock incl bolt, washer as req and 10" locking bar for 12" Grates

GLSS10 - Stainless Steel Grate Lock incl bolt, washer as req and 10" locking bar for 12" Grates

One Grate/Lock needed per Catch Basin, 12"W Grate fits 10" CB, 26"W Grate fits 24" CB

For 4" catch basins, use 05 (5") grates from list above.

Catch Basin Inlets and Outlets

Connection with DTPF4 Trench Drain or Pipes

CBJ4 - Flange for attaching a DTPF4 Trench Drain to a Catch Basin

CBOP4 - Universal Catch Basin Outlet Plate with 4" Pipe Outlet

CBOP6 - Universal Catch Basin Outlet Plate with 6" Pipe Outlet

CBOP8 - Universal Catch Basin Outlet Plate with 8" Pipe Outlet

CBOP12 - Universal Catch Basin Outlet Plate with 12" Pipe Outlet

For 4" SCH40 pipe, no coupling needed. HDPE, SDR35 and 6" SCH40 coupling required, not included.

Catch Basin Trash Baskets

TB4-25 - Stainless Steel Trash Basket to Fit 4" Wide Basin with 1/4" Perforations

TB10-25 - Stainless Steel Trash Basket to Fit 10" Wide Basin with 1/4" Perforations

TB24-25 - Stainless Steel Trash Basket to Fit 24" Wide Basin with 1/4" Perforations

QUESTIONS

If this installation guide does not address your specific question, please feel free to reach out to your local Dura Trench representative or call our customer service team at 770-505-6575.



MANUFACTURING

Eric'sons Manufacturing HQ + Plant #1
296 Industrial Blvd. N
Dallas, GA 30132
770-505-6575

Eric'sons Manufacturing Plant #2
13300 Ramblewood Dr.
Chester, VA 23836

Eric'sons Manufacturing Plant #3
222 W. 33rd St.
Ogden, UT 84401

